

### Description

The SIB116 PMT Sensor Interface Board (SIB) provides the electrical and mechanical connectivity between a Hamamatsu H8711 series 16 channel photomultiplier tube and a Vertilon PhotoniQ multi-channel PMT data acquisition system. The H8711 mounts directly to the bottom of the SIB116 through 37 socket pins and electrical connections to the 16 PMT outputs are made to the SIB connector located on the top of the board. The SIB connector conforms to Vertilon's standard, low-noise, multi-channel, cable interconnection system. It mates to a micro-coaxial cable assembly that connects the 16 PMT outputs to the PhotoniQ. The high voltage connection to the H8711 is made through a separate dedicated connector where a high voltage cable connects between it and the high voltage output on the PhotoniQ.

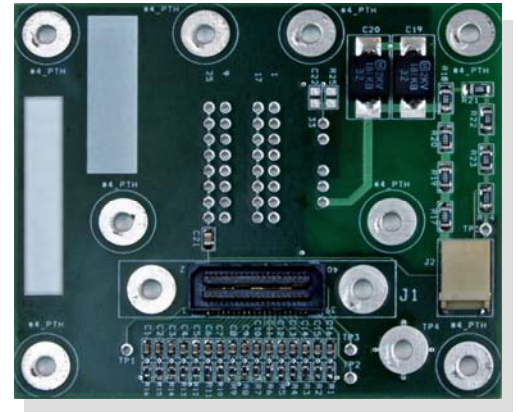

### Typical Setup

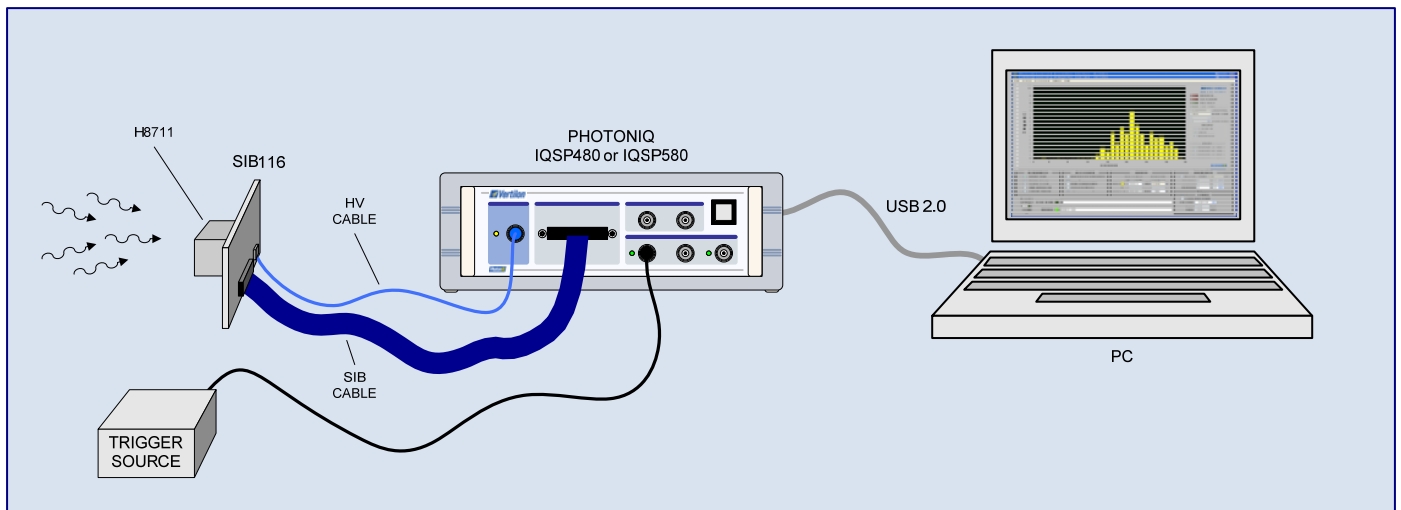

In a typical setup the Hamamatsu H8711 PMT is plugged into the SIB116 Sensor Interface Board which in turn connects to a Vertilon PhotoniQ IQSP480 or IQSP580 multichannel data acquisition system using a SIB cable. When triggered from an external source, the PhotoniQ integrates and digitizes the 16 charge signals from the H8711 and outputs a data packet to the PC over a USB connection. The PhotoniQ also supplies the PMT high voltage bias through a specialized high voltage cable.

Mechanical Data

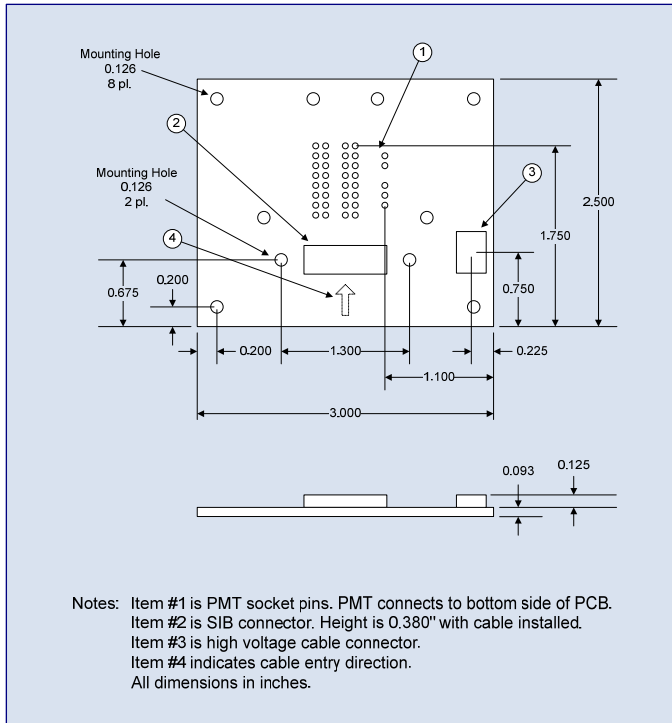

Electrical Data

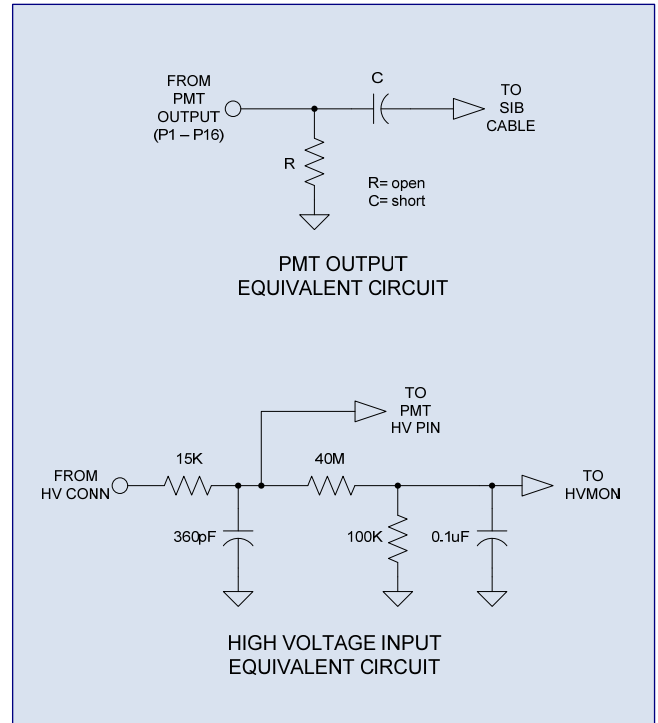

General Safety Precautions

Warning: HIGH VOLTAGES – Voltages can exceed 2000V

Operate device within specified range

Electrostatic discharge sensitive

Do not operate in wet, damp or explosive atmosphere

See Hamamatsu H8711 data sheet for specific handling information

SIB Connector Pinout

#	NAME	#	NAME
1	VB	2	HVMON
3	GND	4	GND
5	P16	6	N/C
7	P15	8	N/C
9	P14	10	N/C
11	P13	12	N/C
13	P12	14	N/C
15	P11	16	N/C
17	P10	18	N/C
19	P9	20	N/C
21	P8	22	N/C
23	P7	24	N/C
25	P6	26	N/C
27	P5	28	N/C
29	P4	30	N/C
31	P3	32	N/C
33	P2	34	N/C
35	P1	36	N/C
37	GND	38	GND
39	SIBDAC	40	+5V

Pins 39 and 40 reserved for PhotoniQ and should be left unconnected if PhotoniQ is not used

Pin 1 grounded when not connected to a PhotoniQ

Ground supplied through SIB cable shielding



Vertilon Corporation has made every attempt to ensure that the information in this document is accurate and complete. Vertilon assumes no liability for errors or for any incidental, consequential, indirect, or special damages including, without limitation, loss of use, loss or alteration of data, delays, lost profits or savings, arising from the use of this document or the products which it accompanies. Vertilon reserves the right to change its products without prior notice. No responsibility is assumed by Vertilon for any infringements of patents or other rights of third parties which may result from the use of its products. No license is granted by implication or otherwise under the patent and proprietary information rights of Vertilon Corporation.

© 2010 Vertilon Corporation, ALL RIGHTS RESERVED

PS2704.2.6 Jul 2010

Vertilon Corporation, 66 Tadmuck Road, Westford, MA 01886 / Tel: (978) 692-7070 / Fax: (978) 692-7010 / [www.vertilon.com](http://www.vertilon.com)